

TATA MOTORS



PRIMA

LX 4928.S HRT

Best Combination of Performance & Reliability



PRIMA
The way the world trucks
Trucks | Tractor-Trailers | Tippers

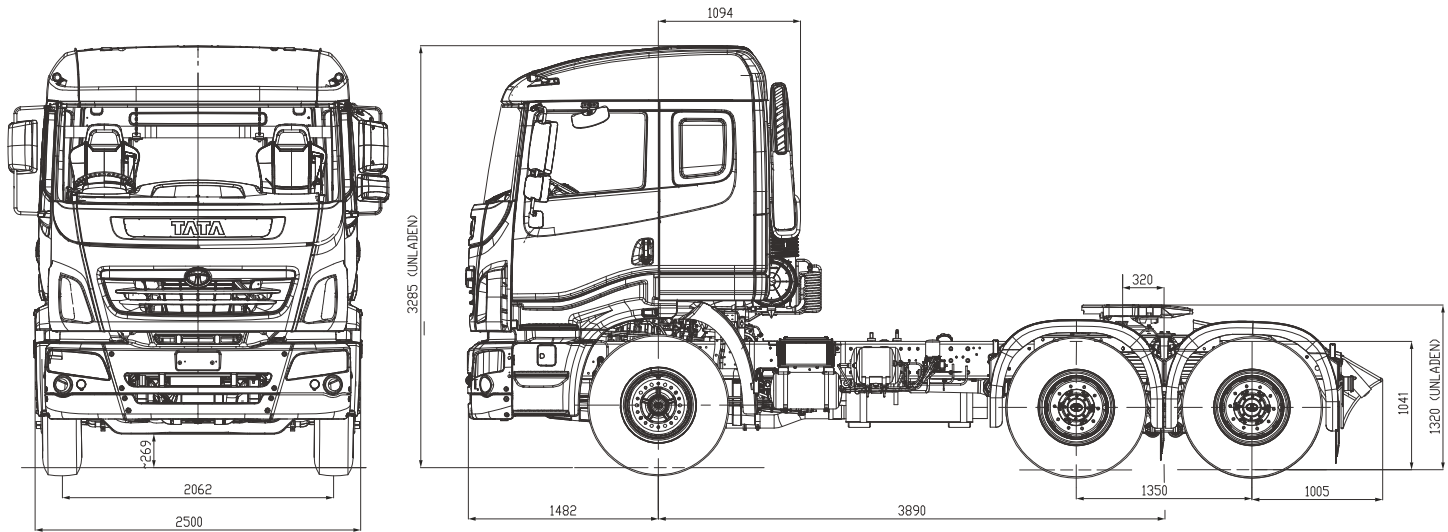

All Dimensions in mm

Engine	
Model	Cummins ISBe 270 BSIII
Type	Water-cooled Direct Injection Turbo-charged, After-cooled Diesel Engine; 6 Inline
Other Details	Bore / Stroke: 107 mm x 124 mm Firing Order: 1-5-3-6-2-4 Air Filter: Dry type remote mounted Oil Filter: Full flow spin on paper type Fuel Filter: Pre and fine filtration with Water Separator
Volume	6700 cc
Power	267 HP @ 2500 rpm
Torque	970 Nm @ 1200-1700 rpm
FIP	HPCR
Cabin & Steering System	
Type	Fully Floating Sleeper Cabin Hydraulic Tilt Type
Steering	Tilt and Telescopic Adjustable Stg. Wheel Dia 470 mm Integral Hydraulic Power-assisted, Ratio: 24.2
Instrument Cluster	Digital
AC	Optional
Tyres	
Tyres	11R20-16PR
Fuel Tank (Itrs)	
Fuel Tank	400
Performance	
Max. Geared Speed in Top Gear (kmph)	77
Max. Gradeability in Crawler Gear	25%
Telematics / GPS Tracking	
Telematics unit as standard fitment Service activation optional (Contact 1800 209 7979)	

Dimensions (mm)	
Overall Width	2585
Overall Length	6968
Wheelbase	3890
Front Overhang	1482
Turning Circle Diameter	14220
Weight (kg)	
Unladen Weight	9235
Max. GCW	49000
Max. FAW	6000
Max. RAW	19000
Gearbox & Clutch	
Model	G1150 DD 9-speed Synchromesh on all forward speeds, Constant mesh on reverse
Speed	8F+1 Cr+1R
Gear Ratios	Crawler - 12.866 1st - 9.138, 2nd - 6.725 3rd - 4.903, 4th - 3.571 5th - 2.559, 6th - 1.883 7th - 1.373, 8th - 1.0, Rev - 13.39
Clutch Type	Single Disc, Dry Friction Type
Clutch Dia	430 mm Push Type, Area - 1984 sq cm
Rear Drive Axle	
Type	Tata HRT 210 Hub Reduction Axle, Fully Floating
Axle Ratio	6.492
Chassis & Suspension	
Size	286 x 90 x 7
Type	Fully reinforced
Front Suspension	Parabolic Leaf 90 mm Width
Rear Suspension	Inverted Bogie Suspension
Brake	
Type	Full Air S - Cam Dual Circuit with ABS